

AMEREC STEAMBATH GENERATORS MODELS AK17, AK20, AK30, 3K20, 3K24, 3K28 & 3K36

(AK/3K "MASTER" GENERATOR TO BE GANGED WITH ONE OR TWO AG/3G "SLAVE" GENERATORS)

AK17 = AK10 + AG7 + Appropriate Control Kit

AK20 = AK10 + AG10 + Appropriate Control Kit

AK30 = AK10 + (2) AG10 + Appropriate Control Kit

3K20 = 3K12 + 3G8 + Appropriate Control Kit

3K24 = 3K12 + 3G12 + Appropriate Control Kit

3K28 = 3K14 + 3G14 + Appropriate Control Kit

3K36 = 3K12 + (2) 3G12 + Appropriate Control Kit

SAVE THESE INSTRUCTIONS. READ ALL INSTRUCTIONS CAREFULLY BEFORE INSTALLATION. POST "WARNING" LABEL OUTSIDE STEAMBATH FOR SAFETY WARNINGS. REQUIRED POSTING ON DOOR OF STEAM ROOM OR ADJACENT TO DOOR FOR ALL COMMERCIAL INSTALLATIONS.

SECTION 1: GENERAL INFORMATION

AMEREC Steam Generators are listed by Underwriters Laboratories. The Steam Generators come assembled and ready for installation. Check that the size and rating of the Generator is suitable for your application, refer to the Steam Room Construction and Generator Sizing Guide (AMEREC document 4211-33).

The AG and 3G line of AMEREC Steambath Generators are "Slave" Generators which can not operate as stand alone generators. These generators can only be controlled by an AK or 3K generator which will function as a "Master" generator. Up to two generators can be "ganged" with, or controlled by, a single AK or 3K generator. The sole purpose of ganging is to increase the volume of steam generated without using multiple controls. Control signals are passed from the AK/3K generator to the "Slave" generator(s) via the cable(s) provided with the "Slave" generator(s).

IMPORTANT

An exhaust fan installed outside the steam room is strongly recommended to remove excess steam from the bathroom or shower area.

WARNING

Electrical grounding is required on all AMEREC Steambath Generators.

All electrical supplies should be disconnected when servicing Generator.

All wiring must be installed by a licensed electrical contractor in accordance with local and national codes.

All plumbing must be installed by a licensed plumber in accordance with local and national codes.

Generators are for indoor use only.

Generators are not for space heating purposes.

Be certain that steambath enclosures are properly sealed to avoid water damage from escaping steam. It is recommended that 100% silicone caulk be used to seal all pipes and fittings. Steam must be prevented from escaping into the wall cavity.

Never shut off the water to a Steam Generator that is in use.

WARNING

REDUCE THE RISK OF OVERHEATING AND SCALDING

1. Exit immediately if uncomfortable, dizzy or sleepy. Staying too long in a heated area is capable of causing overheating
2. Supervise children at all times
3. Check with a doctor before use if pregnant, diabetic, in poor health or under medical care.
4. Breathing heated air in conjunction with consumption of alcohol, drugs or medication is capable of causing unconsciousness.

CAUTION! Do not contact steam head. Stay at least 12" away from hot steam escaping from the steam outlet.

REDUCE THE RISK OF SLIPPING AND FALL INJURY

Use care when entering or exiting the steam room, floor may be slippery

NOTE: For additional safety instructions, see owner's manual.



IMPORTANT SAFETY INSTRUCTIONS

1. READ AND FOLLOW ALL INSTRUCTIONS.
2. WARNING - To reduce the risk of injury, do not permit children to use this product unless they are closely supervised at all times.
3. WARNING - To reduce the risk of injury:
 - a. The wet surfaces of steam enclosures may be slippery. Use care when entering or leaving.
 - b. The steam head is hot. Do not touch the steam head and avoid the steam near the steam head.
 - c. Prolonged use of the steam system can raise excessively the internal human body temperature and impair the body's ability to regulate its internal temperature (hyperthermia). Limit your use of steam to 10 - 15 minutes until you are certain of your body's reaction.
 - d. Excessive temperatures have a high potential for causing fetal damage during the early months of pregnancy. Pregnant or possibly pregnant women should consult a physician regarding correct exposure.
 - e. Obese persons and persons with a history of heart disease, low or high blood pressure, circulatory system problems, or diabetes should consult a physician before using a steambath.
 - f. Persons using medication should consult a physician before using a steambath since some medication may induce drowsiness while other medications may affect heart rate, blood pressure and circulation.
4. WARNING - Hyperthermia occurs when the internal temperature of the body reaches a level several degrees above the normal body temperature of 98.6 degrees F. The symptoms of hyperthermia include an increase in the internal temperature of the body, dizziness, lethargy, drowsiness and fainting. The effect of hyperthermia include:
 - a. Failure to perceive heat:
 - b. Failure to recognize the need to exit the steambath:
 - c. Unawareness of impending risk:
 - d. Fetal damage in pregnant women:
 - e. Physical inability to exit the steambath: and
 - f. Unconsciousness.

WARNING - The use of alcohol, drugs or medication can greatly increase the risk of hyperthermia.

SAVE THESE INSTRUCTIONS

SECTION 2: SELECT MOUNTING LOCATION

SEE THE PREFERRED DIAGRAM 1 & DIAGRAMS 2, 3, 4 & 5

IMPORTANT

Prior to making a decision on the mounting location, please read through this Installation and Service Instructions Manual completely and take a careful look at all the diagrams.

The AMEREC Steam Generator can be hung on a wall or set on its base.

The best mounting location will satisfy all or most of the following:

1. The steam line must slope to allow condensation to drain. Condensation should drain into the steam room.
2. The steam line should be less than twenty (20) feet long. Ten (10) feet is preferred. Steam lines over twenty (20) feet long should be insulated.
3. The mounting location should minimize the number of bends and elbows in the steam line.
4. The steam line should enter the room at least 12" above the floor or at least 6" above a tub rim or ledge. See Diagram 13.
5. No steam head shall be more than thirty (30) inches above the floor.
6. The steam outlet should be located to avoid potential user contact.
7. The Generator(s) should be installed in a dry, well ventilated area. The space provided should be a least:
 - 7 cu ft for one Generator,
 - 17 cu ft for two Generators and
 - 27 cu ft for three Generators.

IMPORTANT:

- Insulate all steam lines and drain lines within the enclosed space.
- Each Generator must be provided with at least four (4) inches ventilation and control wiring access at the control end.
- Each Generator must be provided with at least twelve (12) inches clearance in FRONT of the louvered front cover.
- There should be at least thirty-six (36) inches in front of each Generator for service access.

Suggested locations are under a vanity, in a closet, attic, crawl space or basement. Preferably in the same room. (Not Subject to Freezing)

8. For minimum distance between Steam Generators, see Diagram 1, 2, 3 & 4.

9. The mounting location must be within a cable length of the Master Generator. See Diagram 5.

NOTE:

Longer Slave control cables are available. Call AMEREC Service Department at 1-800-331-0349

10. The location should provide clearance for service and element removal. See Diagrams 1, 2, 3 & 4.

11. There should be no more than three (3) 90° bends and ten feet of pipe between any Generator's drain outlet and its drain valve inlet. See Diagram 15.

12. The generator should NOT be mounted where freezing may occur.

WARNING

*Do not mount outdoors.
Protect from freezing.*

To reduce the risk of explosion, do not interconnect steam outlets. A separate steam line must be provided for each steam outlet.

Units must be located as to allow access for service.

IMPORTANT

An exhaust fan installed outside the steam room is strongly recommended in order to remove excess steam from the bathroom or shower area.

It is strongly recommended that no exhaust fan be installed inside the steam room, doing so will result in a loss of heat and steam through the exhaust fan and port.

DIAGRAM 1: PREFERRED INSTALLATION

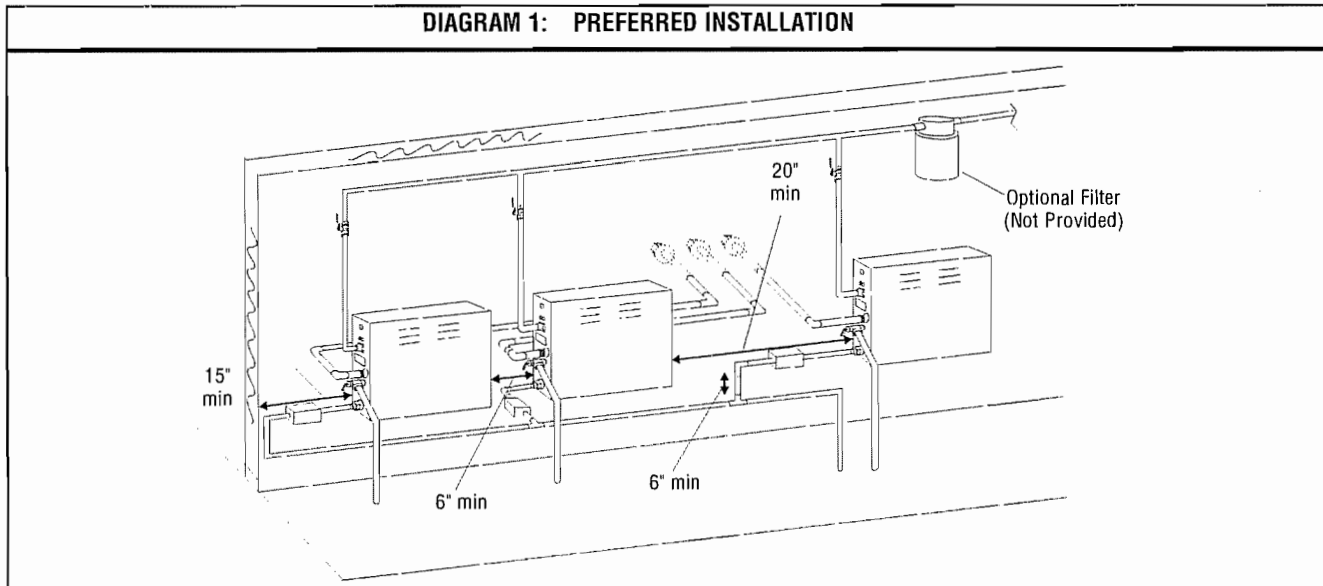

DIAGRAM 2

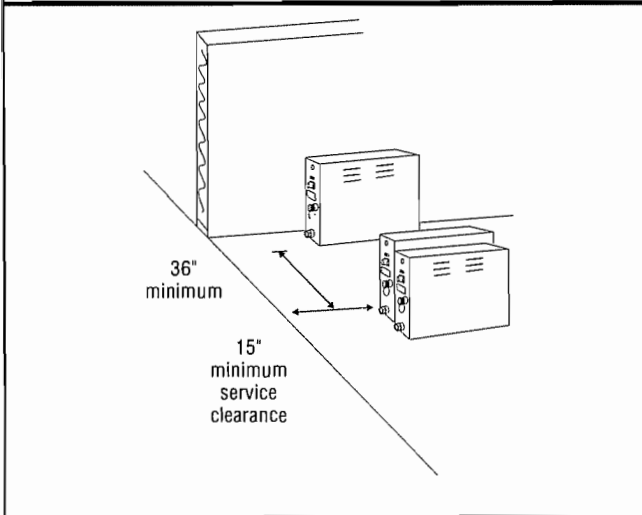

DIAGRAM 3

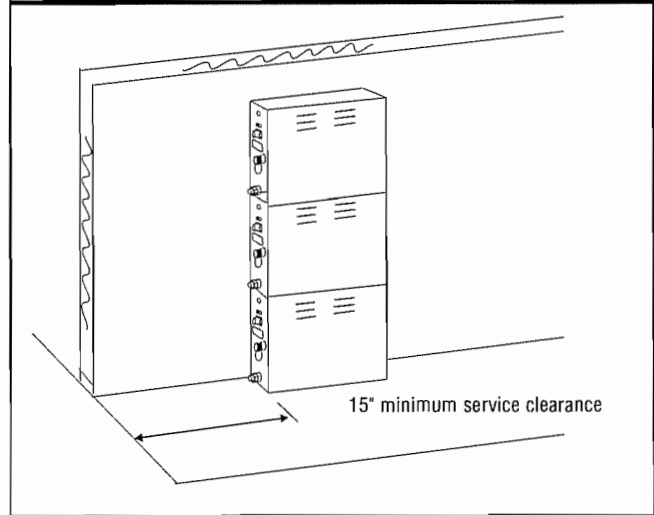

DIAGRAM 4

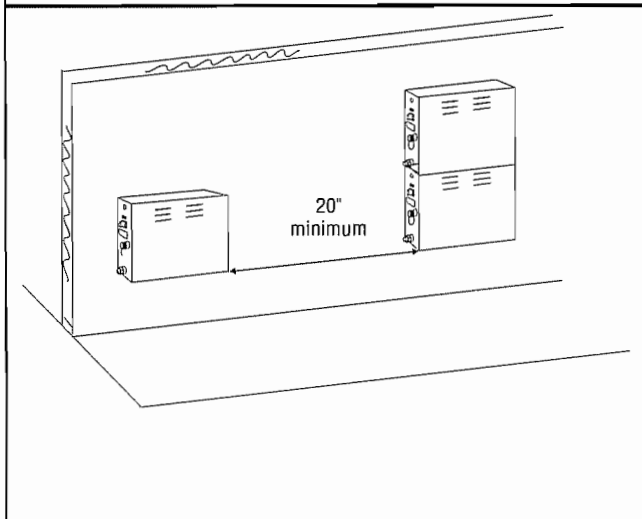
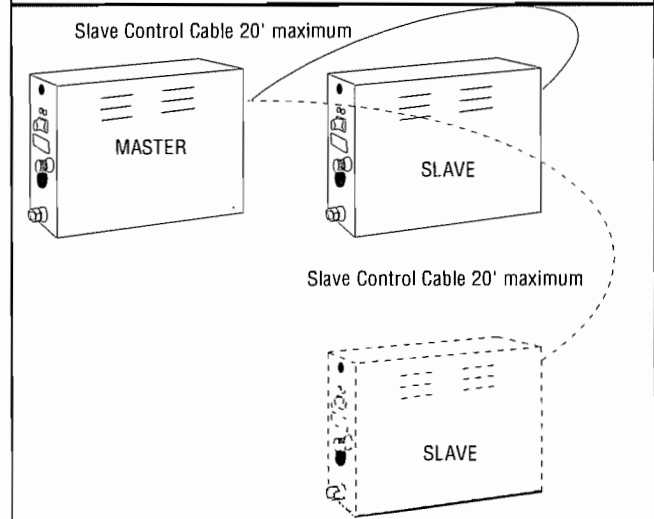

DIAGRAM 5



SECTION 3: MOUNTING THE GENERATOR

Wall Mounting:

1. Note the location of the mounting holes on the back of the Generator. The screws must set directly into studs or equivalent supports. Drill pilot holes on 16" centers and install the two #10 1-1/2 inch screws provided. See Diagram 6.

2. Carefully hang the Generator on two screws. Tighten the screws. Replace the front cover. Secure the front cover with six (6) screws.

3. Mounting should be level.

Floor Mounting:

1. In general the width of the unit allows it to sit on a shelf, across the ceiling joists or on a floor. The Generator must be restrained from moving. Normally the piping will provide adequate support. If not, additional support must be provided.

2. All floor installed Generators must have provision for routine draining of the tank.

3. Mounting should be level.

DIAGRAM 6

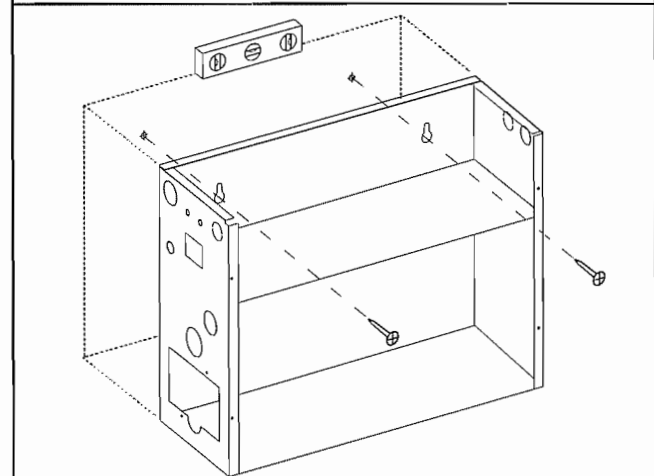

SECTION 4: PLUMBING INSTRUCTIONS

All plumbing shall be installed by a licensed plumber and conform with local & national codes.

Materials (locally available):

- 3/8 inch O.D. copper tube for the water supply to the Generator.
- 3/8 inch water supply shut-off valve.
- 3/8 inch supply housing and filter (optional, depending on local water conditions).
- 3/8 inch O.D. compression to 3/8 inch male NPT adapter.
- 3/8 inch O.D. union
- 1/2 inch copper sweat unions (2).
- 1/2 inch male NPT sweat adapter (2).

- 1/2 inch copper pipe for the tank drain.
- 1/2 inch copper pipe and 1/2 inch male NPT sweat adapter (5) for the steam line between the Generator and the Steam Room, and the drain line between the Generator and the drain.
- 3/4 inch copper pipe, 3/4 inch male NPT sweat adapter, and a sweat union for the Pressure Relief Valve drain.
- Tube DAP 100% silicone caulk.
- Rectorseal No. 5 pipe compound.

NOTE:
Additional materials may be required.

SECTION 4A: INSTALL THE WATER LINE

SEE DIAGRAMS 1 (PREFERRED INSTALLATION, 7 & 8

IMPORTANT

Maximum recommend input water pressure not to exceed 100 PSI

Run 3/8 inch copper tube between the nearest cold water line and the WATER INLET fitting on the Generator. Locate a shut-off valve near the Generator. Connect this line to the Generator with a 3/8" compression adapter. When tightening this fitting always use two wrenches so there will be no strain on the water inlet valve.

IMPORTANT

The Generator will not operate properly, unless it is mounted level with its arrows pointed up.

If the generator is mounted in a place difficult for the homeowner to access, the water supply shut-off valve should be located where it can be quickly accessed in an emergency.

Do not use a saddle valve or saddle fitting for the water supply shut-off valve. Flush water supply line before final hookup.

Do not connect the overpressure device output into the steam line.

Do not connect the drain valve into the steam line.

DIAGRAM 7

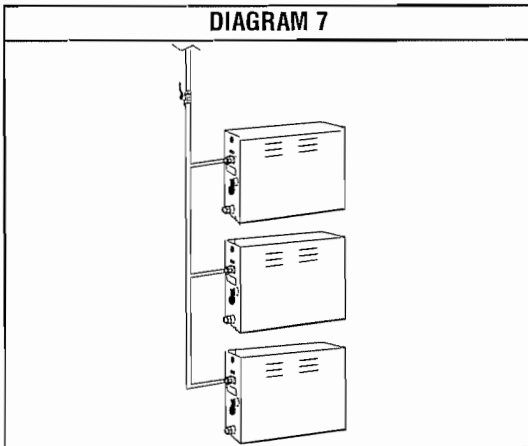

DIAGRAM 8

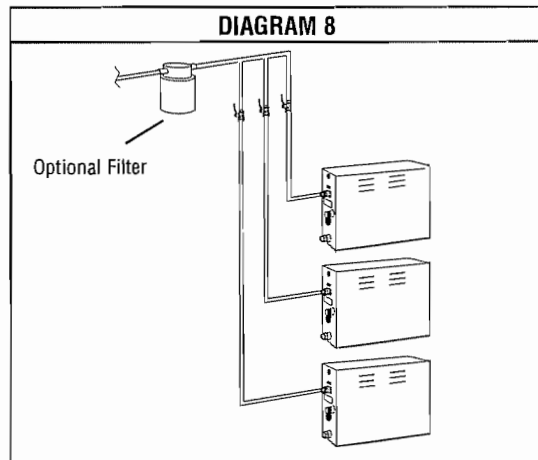

DIAGRAM 9

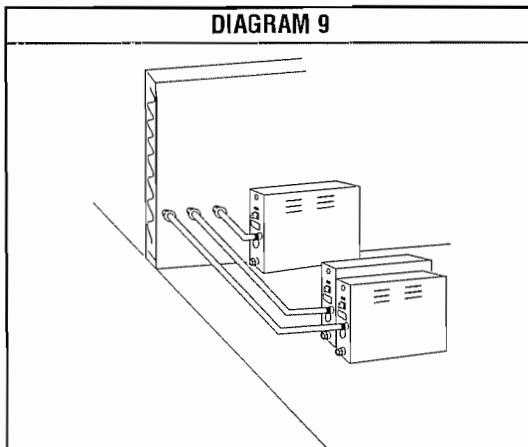
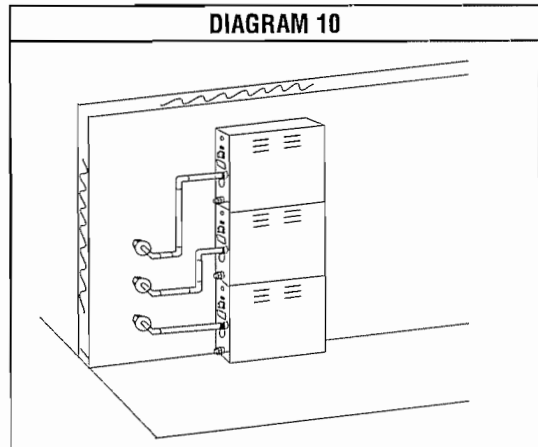

DIAGRAM 10



SECTION 4B: INSTALL STEAM LINE

SEE DIAGRAMS 1 (PREFERRED INSTALLATION) 9 & 10

1. **At the Generator:** Install a 1/2" male NPT sweat adapter. Install a 1/2" sweat union in the steam line.
 - Terminate the steam line with a 1/2" NPT male adapter. Stub the line out into the room 3/8" from the finished surface.
 - Secure the steam line to a structural member.
2. Run the 1/2" copper steam line from the Generator to the Steam Room. Refer to SECTION 2: SELECT MOUNTING LOCATION.
3. The steam line should enter the steam room 12" above the floor or at least 6" above a tub rim or ledge. See diagram 14.
4. **At the steam room:** Drill/prepare a 1-3/8" hole for the steam line entry. Center the 1/2" copper steam pipe in the 1-3/8" hole. See diagram 12.

IMPORTANT

If the steam line is in an area where the temperature will be below 40 F or if the line is more than 20 feet long, best results can be obtained by insulating the steam pipe.

1. **Install steam head insulator:** Apply silicone caulk

SECTION 4C: INSTALL STEAM HEAD

SEE DIAGRAMS 11, 12 & 13

1. **Install steam head:** Place the escutcheon over the steam head insulator then slide the steam head on until the escutcheon rests firmly against the finished wall. Tighten the hex head screw underneath the steam head to secure it in place with the allen wrench provided. The steam head should be level with its fragrance reservoir at the top. See diagram 12.
2. **Install steam head and escutcheon:** Place the Install the pressure relief valve into its port on the

SECTION 4D: INSTALL PRESSURE RELIEF VALVE

Generator. The pressure relief valve outlet must drain in accordance with local and national codes.

SECTION 4E: INSTALL DRAIN LINE(S) AND DRAIN VALVE(S)

SEE DIAGRAMS 1 (PREFERRED INSTALLATION) 14, 15 & 16

1. Automatic drain valves (ADK) or manual drain valves must be supplied for each individual generator unit.
2. Generator drain lines may be ganged together AFTER each individual drain but should not be ganged previous to the drain valve.
3. No generator should have more than three (3) 90 degree bends (elbows or tees) between it and the corresponding drain valve.
4. Drain valves should be within ten (10) feet of the corresponding generator's drain nipple.
5. If the automatic drain valve (ADK) option is installed it must be within three (3) feet of the corresponding generator.
6. Install the 3" nipple (supplied) into drain outlet on generator.
7. Attach the automatic drain (ADK) and/or the manual ball valve to the drain nipple.
8. Install a 1/2" union in the drain line near the drain valves.
9. The drains supplied are gravity flow only therefore all drain lines must be sloped away from the generator.
10. Plumb the drain line to a drain that meets local and national codes. The water exiting the drain may be boiling and WILL present a scald hazard. Use materials rated for boiling water.
11. Because of the scald hazard it is highly recommended that the generator not be plumbed to drain into the shower. Doing so may cause serious injury and may damage shower or steam facility.

DRAINS MUST BE INSTALLED AND CONNECTED IN ACCORDANCE WITH ALL PERTINENT LOCAL AND NATIONAL CODES.

WARNING

Do not put a shut off valve in the steam line. Avoid traps and valleys where water could collect and cause a steam blockage. The hot steam line must be insulated against user contact.

To reduce the risk of explosion, do not interconnect steam outlets. A separate steam line must be provided for each steam outlet.

Centering the steam pipe is critical in rooms made of plastic, acrylic, resin, fiberglass or similar materials. Allowing the steam pipes to touch materials not rated 212° F or higher will result in damage to these materials.

Install the steam head to avoid potential user contact.

Do not install the steam head near bench(es) or where condensation will drip on the user or puddle as this puddling will present a scald hazard.

The steam pipe entry into the Steam Room and the steam head must be caulked to avoid damage caused by steam leakage into the wall.

The pressure relief valve must be installed in such a fashion that the risk of scalding is reduced to a minimum. Draining the pressure relief valve into the Steam Room may present a scald hazard.

Boiling water may be discharged from the drain. Use materials rated for boiling water.

Draining the tank into the Steam Room may present a scald hazard and /or damage materials used to construct the Steam Room.

Electrical shock hazard. Disconnect all electrical power before servicing.

SECTION 4F: Water Quality Requirements

The nature of a boiler or steambath generator requires testing of the feedwater to avoid potential high concentrations of impurities which can cause a deposit or scale to form on the internal surfaces. This deposit or scale can interfere with the equipments proper operation and even cause premature boiler or generator failure. Concentration of impurities is generally controlled by treating the feedwater and or "blowing down" the generator or boiler when it is not heating. The "blow down" process involves removing a portion of the tank water with high solid concentration and replacing it with makeup water.

To insure proper operation, the water supply should be tested prior to operating the equipment. There are several treatment processes which can be used if you have a problem with hard water. A local reliable water treatment company can recommend the appropriate treatment if required. The recommended feedwater quality is listed below.

Feedwater Quality

Hardness, ppm	10 - 30	(.5 - 1.75 gpg)
T-Alkalinity, ppm	150 - 700	(8.75 - 40.8 gpg)
Silica Range, ppm	15 - 25	(1.28 - 1.45 gpg)
PH (strength of alkalinity)	10.5 - 11.5	

DIAGRAM 11

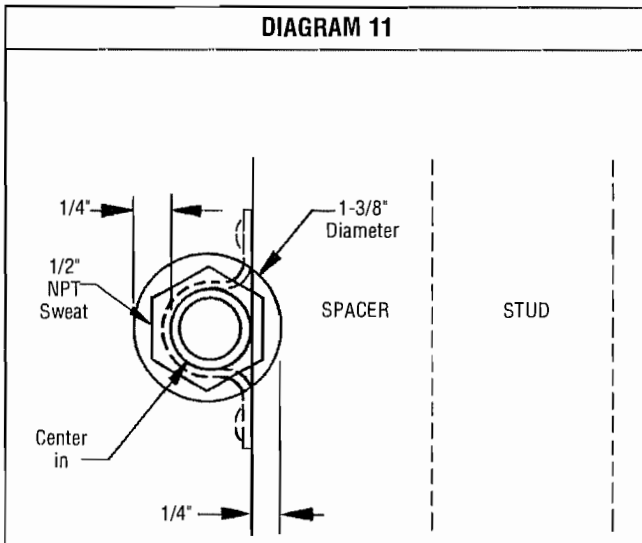

DIAGRAM 12

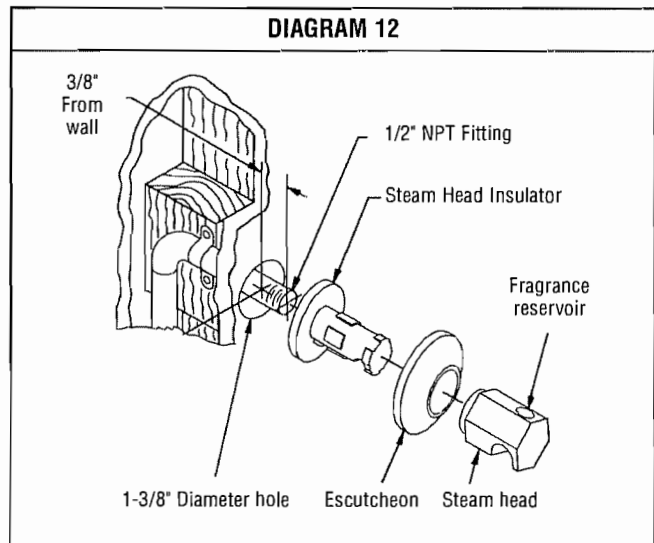

DIAGRAM 13

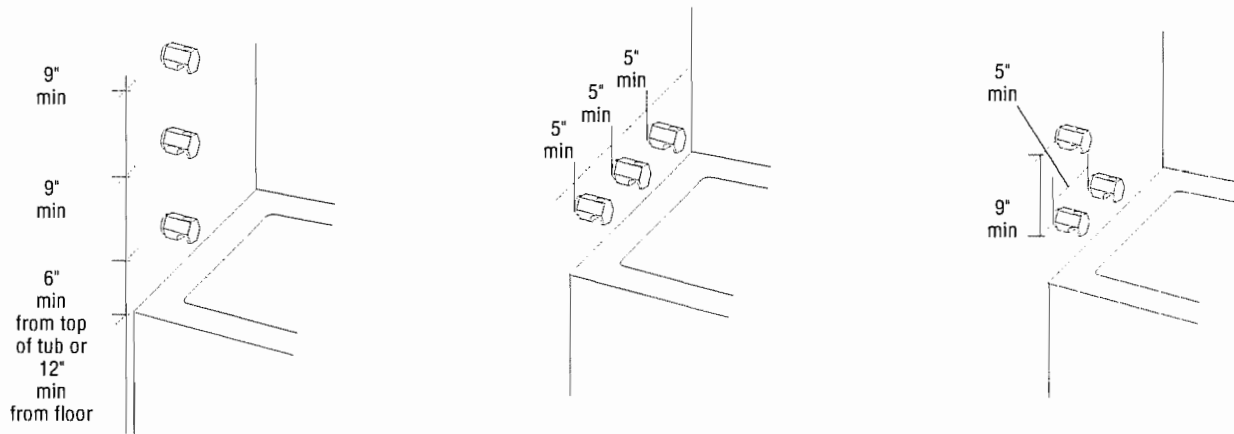

DIAGRAM 14

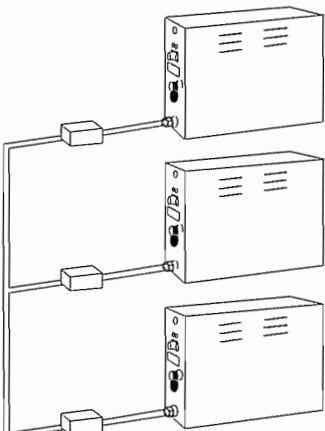

DIAGRAM 15

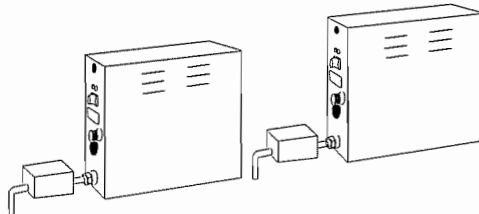
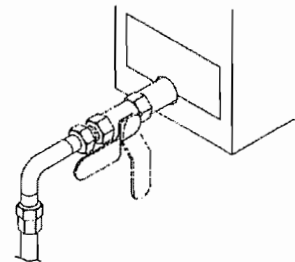

DIAGRAM 16



SECTION 5: WIRING INSTRUCTIONS (All Controls)

SEE ELECTRICAL INFO CHART ON PAGE 9, DIAGRAMS 17 THRU 27
AND WIRING DIAGRAMS ON PAGES 19 & 20

1. CONTROL CABLE ROUGH-IN

The low voltage control can be mounted up to 25 feet from the generator either inside or outside the steam room for the K30, K60 or R30K control but with a built in temperature sensor, the **KT60 must be mounted inside the steam room**, also see #6 optional secondary generator control. String the 25' cable from the control location through 1/2" holes in the wall studs or ceiling joists to the generator. Note: Do not staple through or damage cable. Use factory supplied cables only. Optional for tile rooms, a 2 gang rough-in box may be installed at the desired control mounting location. A mounting plate with proper diameter hole is included with the control kit. Tile up to the hole in mounting plate as indicated in diagram 18 or 22.

2. TEMPERATURE SENSOR CABLE ROUGH-IN (REQUIRED FOR K60 OR K30 ONLY)

It is recommended that the sensor be mounted in the steam room 6" from the ceiling, but not directly over the steam dispersion head or more than 7 feet above the floor. String the sensor cable from the sensor location through 1/2" holes in the wall studs or ceiling joists to the generator location. Leave 12" of slack at the sensor location. Note: Do not staple through or damage cable. Use factory supplied cables only.

3. ELECTRICAL ROUGH-IN

Size wire for the generator as indicated by the Electrical Information Chart on page 9. Use correct size and type to meet electrical codes. Leave 4 feet of slack wire at generator location for finish hookup. Connect the generator to a dedicated circuit breaker. A GFI device is not required by UL. One may be installed if required by local codes or the owner. A GFI device will tend to nuisance trip due to heater element aging.

4. ELECTRICAL FINISH

Materials (locally available):
- 3/4" Strain relief for supply wire.

- A. Route the copper supply wire with appropriate strain relief through the hole marked POWER ENTRY.
- B. Connect the supply wires to terminals marked L1 and L2.
- C. Connect the ground to the ground lug (green screw).

5. INSTALL GENERATOR CONTROL (K30, K60, KT60)

The low voltage controls can be mounted directly to a finished wall either inside or outside the steam room with the exception of the **KT60 control which must be mounted inside the steam room**. Using a 2" hole saw, drill a hole in the finished wall where the control is to be mounted (the control cable should already be roughed-in to this location). With the decorative cover removed from the control switch assembly, insert the two control mounting screws through the control housing (may need to punch through skinned holes) and screw 1/4" into the mounting bracket. Locate the control cable and plug it into the back of the control housing. See diagram 18. Run a bead of 100% silicon caulk in-between the 2 ridges around the perimeter on the back of the control housing. See diagram 19. Insert the mounting bracket into the wall cavity by first pushing with the control housing and then with a hard flat surface on the control housing mounting screws which extend out through the control face. Once the mounting bracket has been inserted into the finished wall, center the control and tighten the mounting screws to draw the control housing securely against the finished wall. Do not over tighten the mounting screws. Install the decorative cover plate by sliding the top of the cover plate over the tab on the top of the control housing and pushing on the bottom of the cover plate to complete the snap fit. See diagram 23. Route the generator end of the control cable through the generator hole marked CONTROL WIRING ENTRY using the strain relief provided. Plug the control cable into the connector on the printed circuit board assembly. Insert cable into connector S30 if a K30 control is used or connector S60A if a K60 or KT60 control is used. See diagram 20.

5A. INSTALL GENERATOR CONTROL (R30K)

The low voltage control can be mounted directly to a finished wall either inside or outside the steam room. Using a 1-3/4" hole saw, drill a hole in the finished wall where the control is to be mounted (the control cable should already be roughed-in to this location). Locate the control cable, pull it out through the 1-3/4" hole and plug the connector on the back of the control housing. Run a bead of 100% silicone caulk around the perimeter on the back of the control housing. See diagram 22. Insert the control into the wall cavity.

WARNING

The KT60 "must" be mounted inside the steam room.

Mount the KT60 48" up from steam room floor.

6. OPTIONAL SECONDARY GENERATOR CONTROL

As an option, a second K60 control can be installed with an AK generator to provide ON/OFF control both inside and outside the steam room. The second control should be installed as described in paragraphs 1 & 5, with the second control cable plugged into connector S60B for the K60 Control on the printed circuit board assembly. See diagram 20.

7. INSTALL TEMPERATURE SENSOR (REQUIRED FOR K60 OR K30 ONLY)

The temperature sensor should be mounted 6" below the ceiling, inside the steam room, but not directly over the steam dispersion head or more than 7 feet above the floor. Using a 7/8" hole saw, drill a hole in the finished wall where the sensor is to be mounted (the sensor cable should already be roughed-in to this location). Locate the sensor cable, pull it out through the hole and plug it into the temperature sensor. It is best to tape the sensor and cable connection together to avoid disconnection inside the wall. Apply silicon caulk as shown in diagram 24 and insert the sensor in the hole. Make sure that the sensor probe is pointing down once installed. Tape the sensor in place while the silicone hardens. Route the generator end of the sensor cable through the generator hole marked CONTROL WIRING ENTRY using the control cable strain relief. Plug the sensor cable into the connector marked J4 on the printed circuit board assembly. See diagram 20

QUICK INSTALLATION CHECK LIST

- | | |
|----|---|
| 1. | DO YOUR BREAKER AND WIRE SIZES MATCH FACTORY/UL SPECS AS PER CHART ON PAGE 9? |
| 2. | IF GENERATOR REQUIRES A TEMPERATURE SENSOR, IS THE SENSOR INSTALLED? |
| 3. | ARE YOUR CONTROL(S) PLUGGED INTO THE CORRECT JACK(S) ON THE CIRCUIT BOARD? |
| 4. | IS POWER SUPPLIED TO ALL CIRCUITS OF STEAMER? (SOME REQUIRE TWO FEEDS) |
| 5. | WAS POWER OFF AT THE BREAKER/DISCONNECT WHEN THE CONTROL(S) WERE INSTALLED? |
| 6. | IS WATER SUPPLIED TO GENERATOR? |
| 7. | IS STEAM LINE PLUMBED TO STEAM ROOM? |
| 8. | IS THE AUTOMATIC DRAIN VALVE INSTALLED IN DRAIN OUTLET LINE OR THE BALL VALVE INSTALLED IN A CLOSED POSITION? |

DIAGRAM 17 (K30 & K60 Controls)

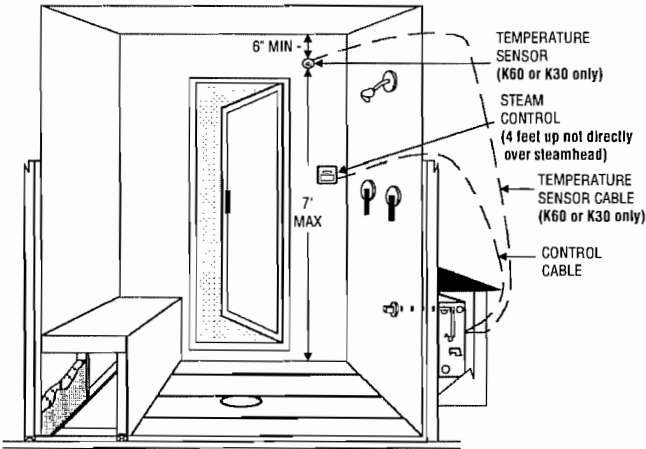

DIAGRAM 18 (K30 & K60 Controls)

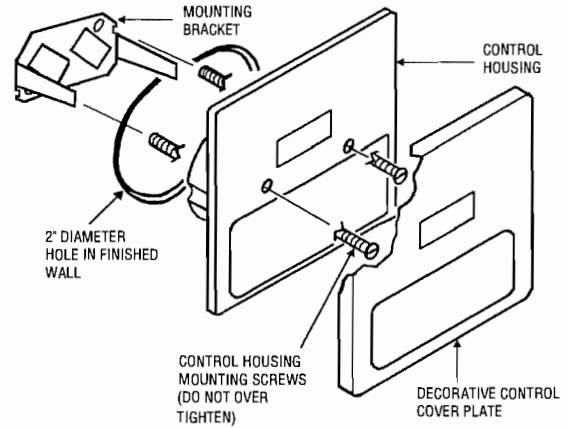

DIAGRAM 19 (K30 & K60 Controls)

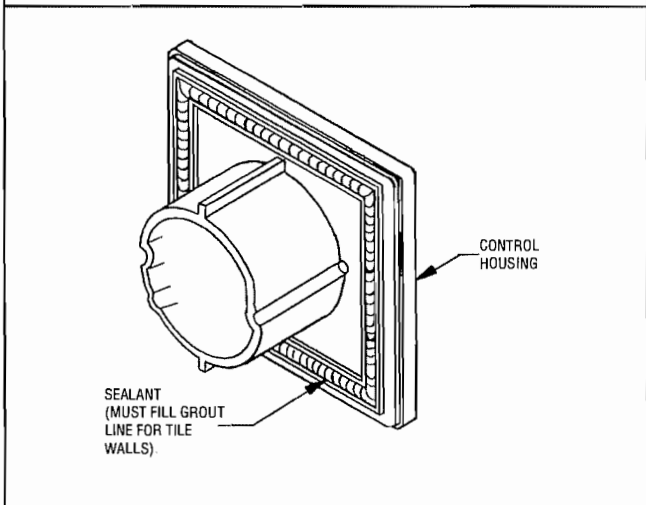

DIAGRAM 20 (K30 & K60 Controls)

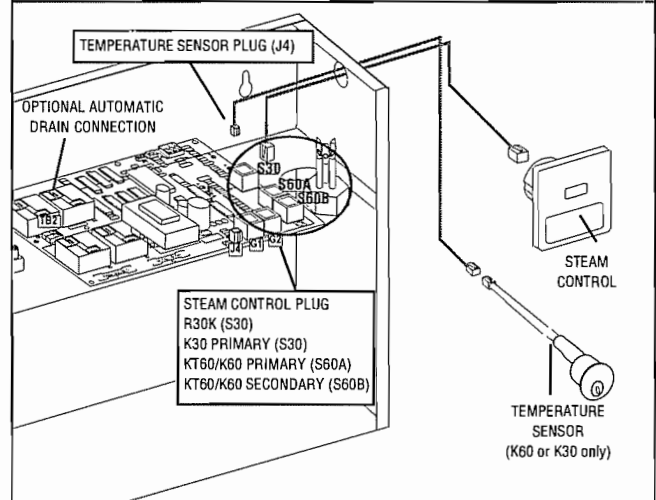

DIAGRAM 21 (R30K Control)

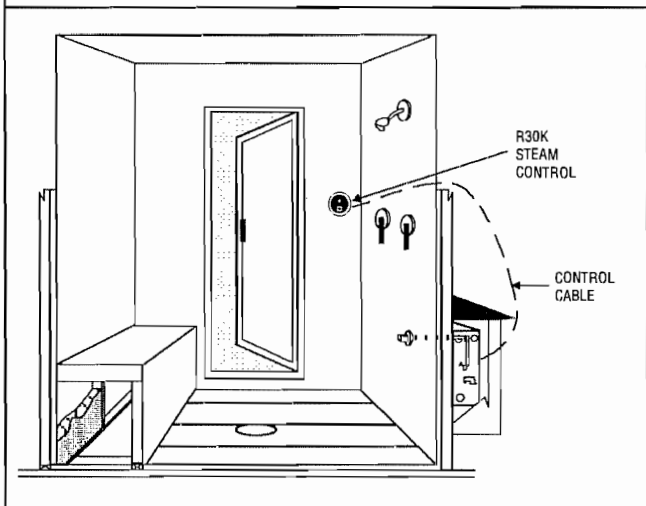
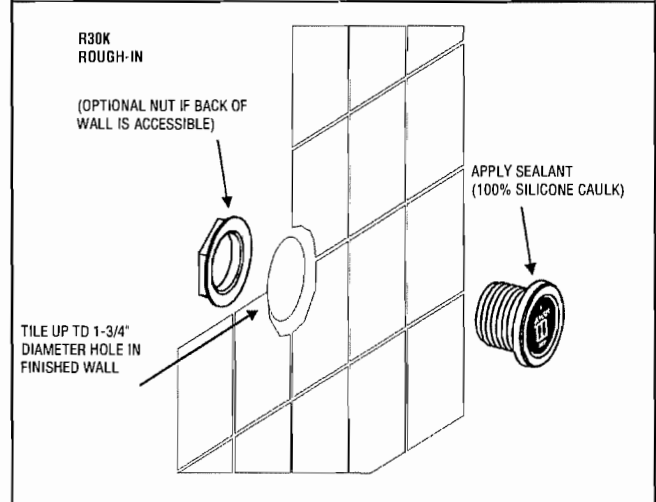
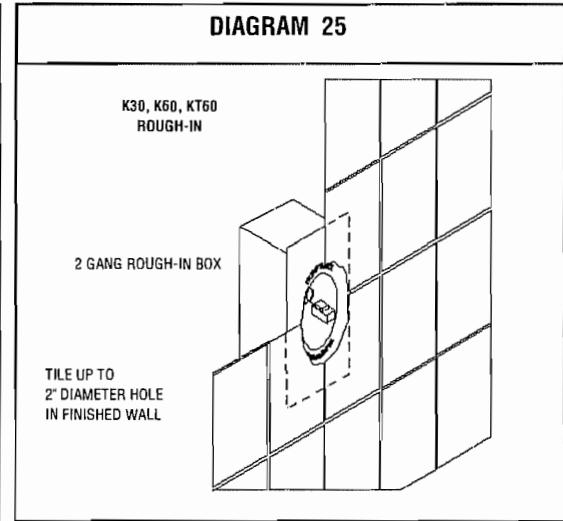
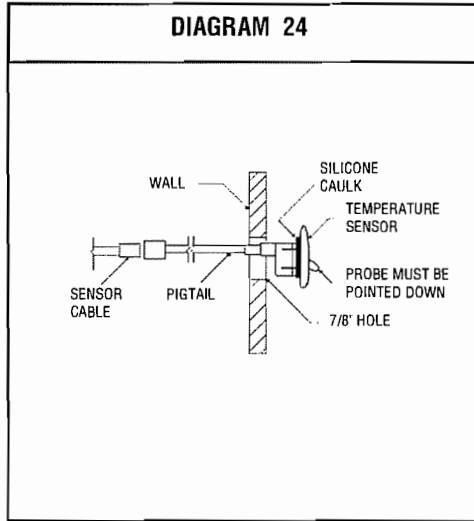
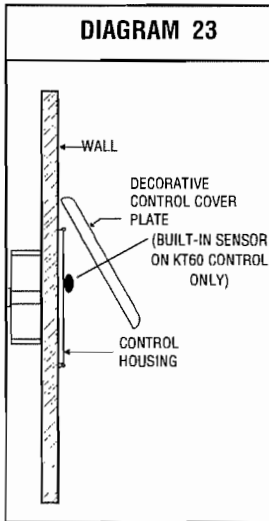

DIAGRAM 22 (R30K Control)





ELECTRICAL INFORMATION CHART

STEAM GENERATOR MODEL NO.	AK10	AG7	AG10	3K12	3K14	3G8	3G12	3G14
AC VOLTAGE	208 / 240	208 / 240	208/240	208	208	208	208	208
PHASE	1	1	1	3	3	3	3	3
NOMINAL WATTAGE @ 208 @ 240	7500 10000	5250 7000	7500 10000	12000 N/A	14000 N/A	8000 N/A	12000 N/A	14000 N/A
NOMINAL AMPERAGE @ 208 @ 240	36.1 41.5	25.3 29.0	36.1 41.5	33.3 N/A	40.1 N/A	21.9 N/A	33.3 N/A	40.1 N/A
UL RECOMMENDED PROTECTIVE DEVICE @ 208 @ 240	50 60	35 40	50 60	50 N/A	60 N/A	30 N/A	50 N/A	60 N/A
RECOMMENDED MIN. COPPER SUPPLY WIRE* @ 208 @ 240	8-2 W/G 6-2 W/G	8-2 W/G 8-2 W/G	8-2 W/G 6-2 W/G	8-3 W/G N/A	6-3 W/G N/A	10-3 W/G N/A	8-3 W/G N/A	6-3 W/G N/A

*Observe wire sizes for 208 VAC installations. 208 VAC wired units must be supplied with a minimum of 195 VAC while operating (heating). Unit is rated for copper wire only. All wire is UL approved 300V 75° deg., minimum unless otherwise specified. LISTED WIRE SIZES ARE MINIMUM FOR REFERENCE ONLY. REFER TO NEC AND LOCAL CODES FOR YOUR INSTALLATION.

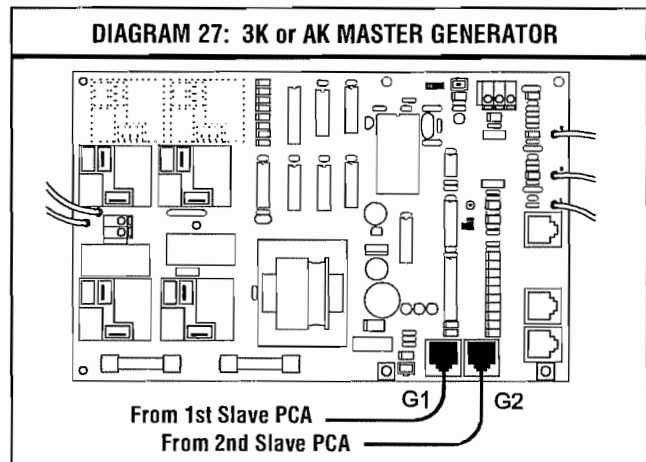
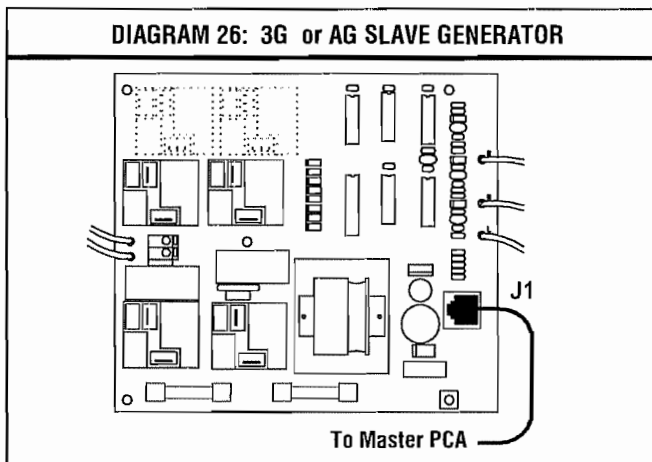

SECTION 5B: WIRING INSTRUCTIONS (SLAVE GENERATORS)

SEE ELECTRICAL INFO CHART ON PAGE 9 DIAGRAMS 26 & 27 AND THE WIRING DIAGRAM ON PAGE 20

1. ELECTRICAL ROUGH-IN

Size wire for the Generator as indicated by the Electrical Information Chart on page 9. Use correct size and type to meet electrical codes. Leave 4 feet of slack wire at Generator location for finish hookup. Connect the Generator to a dedicated circuit breaker. A GFCI device is not required by UL. One may be installed if required by local codes or the owner. A GFCI may nuisance trip due to heater element aging.

2. ELECTRICAL FINISH

Materials (locally available):

- 3/4" Strain relief for supply wire.
- Circuit breaker per Electrical Information Chart.

- a. Route the copper supply wire with appropriate strain relief through the hole marked POWER ENTRY.
- b. Connect the supply wires to the terminal block marked L1 and L2.

- c. Connect the ground wire to the ground lug (green screw on junction compartment wall).

3. INSTALL SLAVE CONTROL CABLE

- a. Route one end of the slave control cable through the Generator hole marked "Control Wiring Entry". Use the strain relief provided. Plug the slave control cable into the connector J1 on the slave PCA. See Diagram 26.
- b. Connect the other end of the slave control cable to the Master Generator. See Diagram 27.

SECTION 6: OPERATIONAL TEST

1. Assure power and water are on.
2. Press the ON/OFF. The control should light-up.
3. Allow 10 minutes for the steam to start.
4. Once the steam starts, press the ON/OFF. The steam should stop; there shouldn't be any water flow. The control should not be lit-up.
5. Press the ON/OFF. The control should light up.
6. Within one minute the unit should again produce steam. It should call for water once every two minutes

or more depending on its power rating. It's normal for the flow of steam out the steam head to slow for up to 10 seconds each time the unit calls for water.

7. The unit will shut down automatically in 30 minutes if the R30K or K30 Control is used, or up to 60 minutes if the K60 or KT60 Control is used. When the time runs out the steam will stop and there should not be any water flow. The control should not be lit.

8. If the unit does not operate as described above, refer to SECTION 8: TROUBLESHOOTING GUIDE.

THE UNIT IS NOW READY FOR OPERATION.

WARNING

Electrical shock hazard - Disconnect all electrical power before servicing the Generator. All wiring should be installed by a licensed electrical contractor in accordance with local and national codes.

The Generator is designed for hookup with copper wire only

User Shock Hazard! Installer must maintain control wiring segregation. All control wiring must be restrained in the "Control Area" designated in Diagrams 26 & 27.

*Protect the AG cable per local codes if it is routed in:
 Areas exposed to weather;
 Chemical or hazardous atmospheres; Areas that may exceed their temperature ratings or... if routed adjacent to wires with voltage above 240V.*

SECTION 7: SERVICE

SEE DIAGRAMS 28 THRU 32 AND WIRING DIAGRAMS ON PAGES 20 & 21

1. DESCRIPTION OF AMEREC (SLAVE) SERIES GENERATOR

The AG Slave is controlled by an "AK or 3K" Master Generator. Control signals are transmitted to the Slave from the Master via the 8 wire slave control cable provided.

The AK or 3K Printed Circuit Assembly provides the interface circuitry between the AK Master and the Slave Printed Circuit Assembly. The Slave PCA provides the basic functions necessary to produce steam. It controls makeup water, provides a water level permissive for powering the elements and provides raw DC power for the system.

2. MAINTENANCE OF GENERATOR

VISUAL INSPECTION - Whenever the Generator is opened inspect for any evidence of water leaks. Inspect the wiring for any evidence of overheating. Check all electrical connections for tightness.

FLUSH TANK - Flush monthly, or more often, depending on local water conditions.

1. The Generator should be cool
2. Press th ON/OFF. The control should light
3. Open the manual drain valve
4. The unit will drain without heating the water
5. Allow the water to run for a full 10 minutes, then press the ON/OFF. The control light should turn off
6. Allow the unit to drain completely. When the water stops, close the drain valve

3. REPAIR OF GENERATOR

a. ELEMENT REPLACEMENT

Disconnect power from the unit. Drain the tank. Open the front and HEATING ELEMENT ACCESS covers. Note the wire connections. See Diagram 28. Remove the element wires. Using a hot water element socket, remove the element. To install a new element, mount a new element gasket on the element. Clean the element port and add a light coat of Rectorseal No. 5 pipe thread compound to the threads. Insert and hand tighten the element-gasket combination. Notice the element end orientation as shown in Diagram 29. Tighten the element until the orientation is the same as Diagram 29, $\pm 15^\circ$. The gasket should be set and tight but not deformed to a rounded or bulbous appearance. If the drain valve was removed reinstall it. Reconnect the wiring. Test the unit per SECTION 6: OPERATIONAL TEST. Check for leaks at the element. Replace the front cover and the HEATING ELEMENT ACCESS cover.

b. PRINTED CIRCUIT REPLACEMENT

Printed circuit assembly (PCA) removal and replacement must be performed in the sequence described below. Any other method can damage the PCA's.

IMPORTANT

The PCA's contain static sensitive devices. Static electricity may damage PCA's. Handle accordingly.

To remove the PCA: Disconnect power from the unit. Note and tag the positions of all wires that plug into the printed circuit assembly mounted relays. Remove all the wires from the relays. When removing these wires, pull on the connector, not the wire. Disconnect all three (3) wires from the water level probe. Next slide these wires out by slightly bending the wire clamp retaining these wires. Disconnect the two (2) blue wires from the water solenoid valve. Five (5) or seven (7) stand offs hold the board in place. Remove all the stand offs by pinching the tops. When it is completely disconnected, it may be lifted out of the enclosure. See Diagram 30. To install the board, reverse this procedure. Test the unit per SECTION 6: OPERATIONAL TEST.

IMPORTANT

The blue wire connected to "L" and "P3" on the PCA must be connected to the shortest of the three level probes.

c. WATER SOLENOID REPLACEMENT:

Disconnect power from the unit. Turn the water supply OFF. Disconnect the water supply from the water solenoid valve. Remove the front cover. Remove the two blue wires from the water solenoid valve. Rotate the self-tightening hose clamp so it can be loosened with a pair of pliers. Squeeze the clamp and move it down towards the shelf and off the valve outlet tube. Remove the two 1/4" - 20 hex head bolts and lock washers that attach the valve to the chassis. Pull the valve off the rubber fill hose. To install the valve, reverse these instructions. Test the unit per SECTION 6: OPERATIONAL TEST.

d. LEVEL PROBE REPLACEMENT:

Disconnect power from the unit. Remove the front cover. Disconnect all three (3) wires from the water level probe. Using a 1-1/4" box wrench, remove the level probe. Install a new level probe. Tighten until the bottom of the plastic nut is 1/8" to 3/8" inch above the top of the port. See Diagram 32. Reattach the three (3) wires. Test the unit per SECTION 6: OPERATIONAL TEST.

IMPORTANT

The blue wire connected to "L" and "P3" on the PCA must be connected to the shortest of the three level probes.

IMPORTANT

The level probe may be extremely tight. Damage to the insulation or chassis may result unless the tank is properly blocked or supported during probe removal or installation. It may be necessary to completely disconnect and disassemble the Generator.

WARNING

All electrical supplies should be disconnected before servicing Generator.

For continued safe operation use factory authorized replacement elements only.

Electrical Shock Hazard. PCA's have exposed 208/240 VAC on them. Disconnect 208/240 VAC power to the generator before servicing.

The relays may be damaged if the correct orientation of the connectors is not observed. See Diagram 31.

DIAGRAM 28

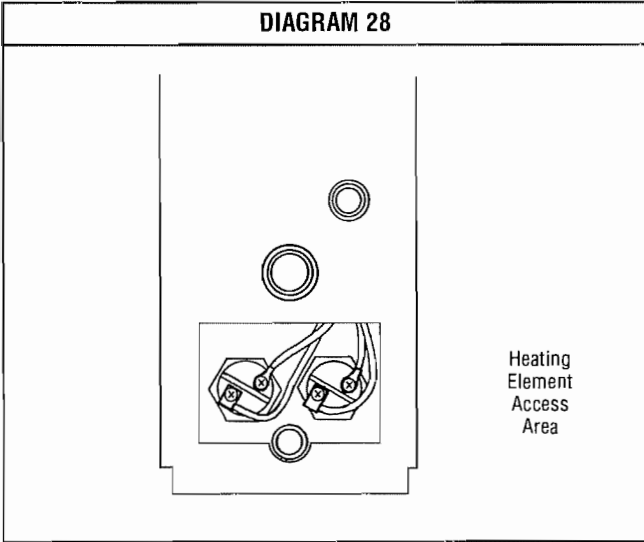

DIAGRAM 29

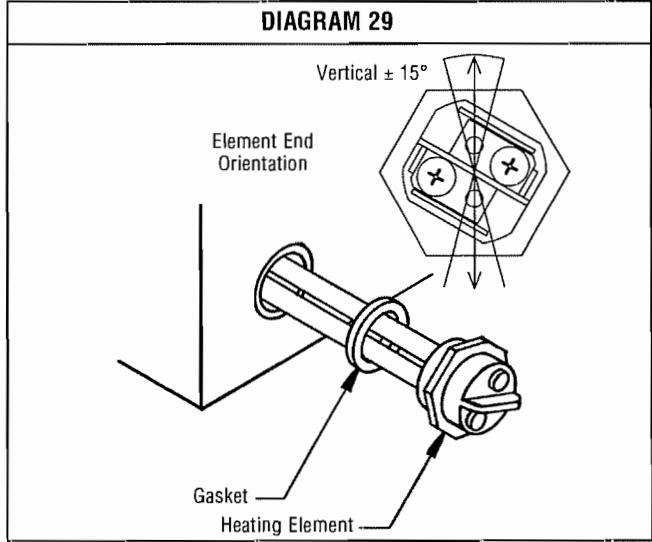

DIAGRAM 30

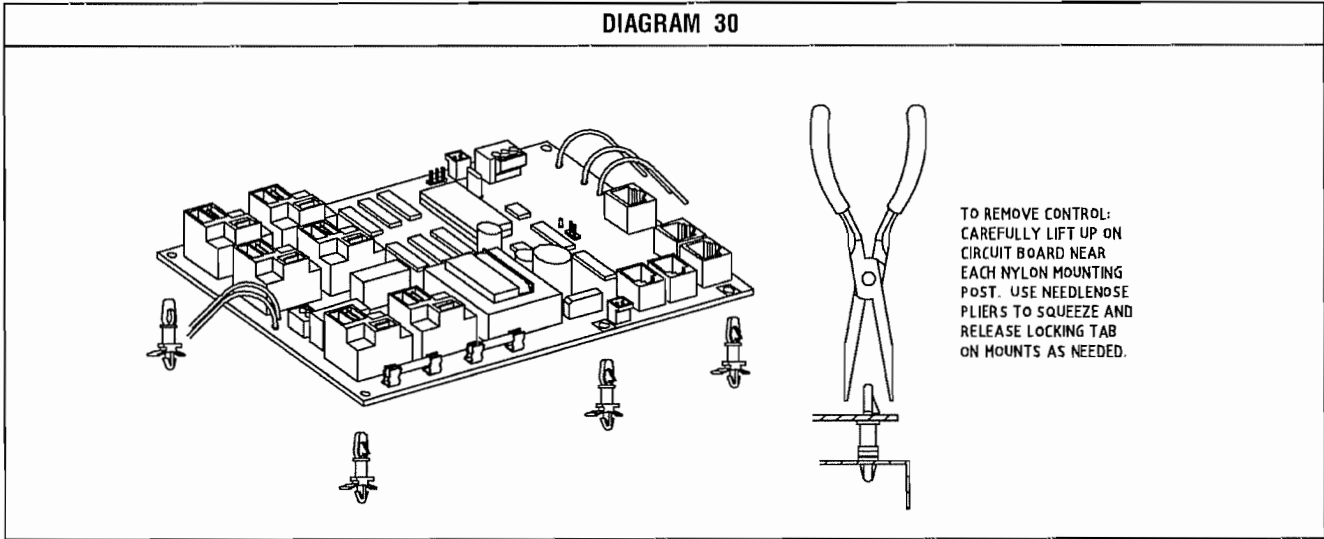

DIAGRAM 31

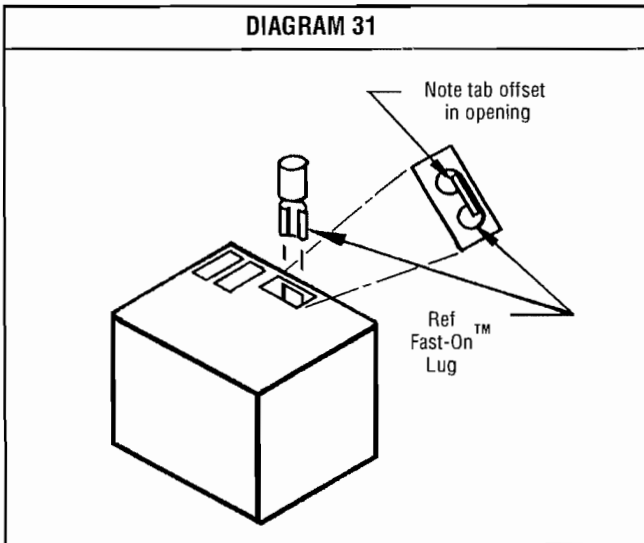
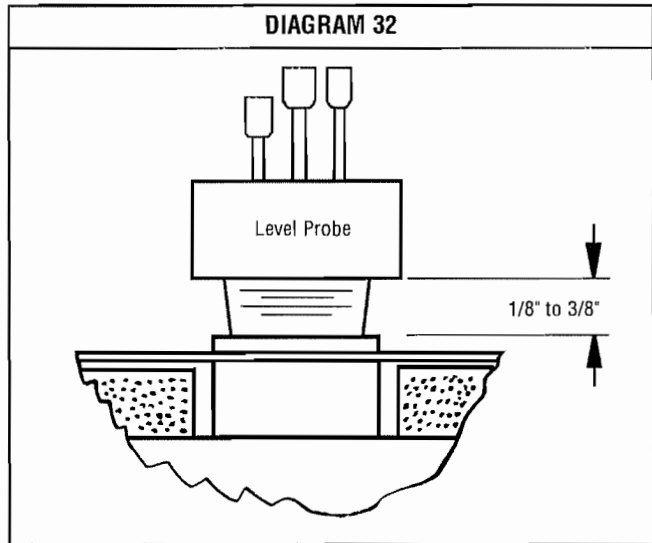

DIAGRAM 32



SECTION 8: TROUBLESHOOTING GUIDE

There are no user serviceable parts in the Generator. All repair should be performed by a qualified service person. For additional assistance or the factory authorized service person nearest you call, AMEREC Service Department at 1-800-331-0349. The Troubleshooting Guide below is meant as a general aid only. Follow ACTION TO BE TAKEN in order until the problem is resolved. Where replacements or repairs are indicated, see the appropriate paragraph of SECTION: 7 SERVICE.

TABLE I

SYMPTOMS	PROBABLE CAUSES	ACTION TO BE TAKEN
Control won't turn "ON" (Control light off). Note: Control Cables must be correctly plugged in before power is turned on.	Improper power supplied (no power). or Control improperly connected. or AK or 3K "PCA" printed circuit assembly is faulty. or Control cable is faulty. or Control is faulty.	1. a. Make sure circuit breaker is "ON", 208/240V supplied. b. Using a voltmeter, check the voltage across the two fuses on the "PCA" printed circuit assembly. Voltage should be 208V. c. Check fuses on the PCA. If fuse(s) are blown, replace with Buss# MDL 15/100 or equivalent fuse. If the fuse blows again - call AMEREC's Service Department. 2. Turn off power to the generator. 3. Check control(s) installed per Section 5. Re-apply power and test operation. 4. Replace AM PCA printed circuit assembly - call AMEREC's Service Dept. 5. Replace control cable - call AMEREC's Service Department. 6. Replace the control - Call AMEREC's Service Department.
Master unit is inoperable. Slave unit(s) are OK.	AK or 3K Master PCA unit is faulty	Call AMEREC Service Department
Master unit is OK. The only Slave unit is inoperable.	AK or 3K Master PCA unit faulty or Slave control cable is faulty or Slave unit is faulty	1. Make sure the Slave control cable is connected. 2. In the Master unit move the Slave control cable to the unused connector on the AM PCA. 3. a. If symptoms disappear replace the AM PCA. If problem remains call AMEREC Service Dept. b. If symptoms remain the same, go to Table II.
Master unit is OK. One of 2 Slave units is inoperable.	AK or 3K Master PCA unit faulty or Slave control cable is faulty or Slave unit is faulty	1. In the Master unit swap the Slave control cables on the Master PCA. 2. If the symptoms move to the other Slave unit replace the Master PCA. 3. If the symptoms remain the same, swap the Slave Generator ends of the Slave control cable between the Slave units. 4. If the symptoms move to the other Slave unit, the Slave control cable connected to the inoperable Slave unit is faulty - replace it. 5. If the symptoms remain the same, go to Table II.
Master unit is OK. Both Slave units are inoperable.	Slave control cables are faulty or AK or 3K Master PCA unit is faulty	1. Make sure that the Slave control cables are connected. 2. Replace the Master PCA unit

TABLE II

SYMPTOMS	PROBABLE CAUSES	ACTION TO BE TAKEN
Master control "OFF". Water won't shut off and runs out of the Slave unit's steam head.	Water solenoid valve is stuck open or AG PCA is faulty or Slave control cable is faulty or AK or 3K Master PCA unit is faulty	1. Turn off power to the Slave Generator. If the water stops, go to step 3. 2. a. Remove the water solenoid valve, disassemble, clean, re-assemble, and check for proper operation. b. Replace valve. If problem remains call AMEREC Service Department. 3. a. Unplug the Slave control cable connected to the Slave unit. b. Turn ON power to the Slave unit. c. If water stops running, replace the PCA in the Master unit. d. If the water doesn't stop running, Call AMEREC Service Department.

TABLE II Con't.

SYMPTOMS	PROBABLE CAUSES	ACTION TO BE TAKEN
Master control "ON". Water won't shut off and runs out of the Slave unit's steam head.	Connection between the blue wire and the water level probe is faulty or AG/3G PCA is faulty or Slave control cable is faulty or AK or 3K Master PCA unit is faulty	<ol style="list-style-type: none"> 1. Check the green ground wires to the Slave tank and the PCA. Note: Not used on later models. 2. Check that the blue and white wires are properly attached to the water probe. 3. <ol style="list-style-type: none"> a. Unplug the Slave control cable connected to the Slave unit. b. If water stops running, replace the PCA in the Master unit. c. If the water doesn't stop running, Call AMEREC Service Department
Master Unit steams. Slave unit won't steam	Improper or no power supplied or No water supplied or Plugged water solenoid valve or Water level probe is faulty or Burnt out heating elements or AG/3G PCA is faulty or Slave control cable is faulty or AK or 3K PCA in the Master unit is faulty	<ol style="list-style-type: none"> 1. <ol style="list-style-type: none"> a. Make sure the circuit breaker to the Slave unit is "ON". b. Using a voltmeter, check the voltage across the two fuses on the Slave PAL. Voltage should be 208/240V. c. Check fuses on the Slave PAL. If fuse(s) are blown, replace with Buss MDL 15/100 or equivalent fuse. If the fuse blows again - call Nasscor's Service Department. 2. Check for proper water supply (supply valve "ON") to Slave unit. 3. Check for Slave (or common) drain valve closed. 4. <ol style="list-style-type: none"> a. Push the Master unit's control "OFF". b. Open the Slave (or common) drain valve allowing tank to drain completely. c. Close the drain valve. d. Push the Master unit's control "ON". e. Unit will begin filling. Listen for a click noise on the Slave unit. Within 20 seconds after click noise is heard, the water fill will shut off. This will indicate the Slave tank is full. Go to step 7. If the tank does not fill - See SYMPTOMS: "Slave unit won't fill up". 5. If the Slave tank has filled but the relay click was not heard, temporarily ground the two long probes of the water level probe. If the click is heard as both the probes are grounded, check probe wiring, if ok replace the level probe. If the click is not heard go to step 6. 6. Call AMEREC Service Department.
Master unit "ON". Slave tank drained. Slave unit won't fill up.	Improper or no power supplied or No water supplied or Plugged water solenoid valve or Water solenoid valve faulty or Level probe faulty or AG/3G PCA faulty or Slave control cable faulty or AK or 3K PCA in the Master unit is faulty	<ol style="list-style-type: none"> 1. <ol style="list-style-type: none"> a. Make sure the circuit breaker to the Slave unit is "ON". b. Using a voltmeter, check the voltage across the two fuses on the Slave PCA. Voltage should be 208/240V. c. Check fuses on the Slave PCA. If fuse(s) are blown, replace with Buss MDL 15/100 or equivalent fuse. If the fuse blows again - call AMEREC Service Department. 2. Check for proper water supply (supply valve "ON"). Check for drain valve closed. 3. Remove the blue wire from the level probe. If the unit fills, clean or replace the level probe. 4. Reconnect the blue wire to the shortest level probe. At the water valve solenoid, slide back the red connector enough to get the voltmeter probes on the solenoid terminals. Measure the voltage across the solenoid terminals. If it is not 208/240V, replace the PCA. If 208/240V is found, proceed with steps 5 & 6. 5. Remove water solenoid valve: disassemble, clean, reassemble and check for proper operation. 6. Replace the water solenoid valve. 7. Call AMEREC Service Department.
Water continually sputters out of any steam head	Foaming containinants in the water supply	<ol style="list-style-type: none"> 1. Flush tank 3 times. See Section 8: FLUSHING PROCEDURE. 2. Call AMEREC Service Department.

DIAGRAM 33 (AK/3K GENERATOR)

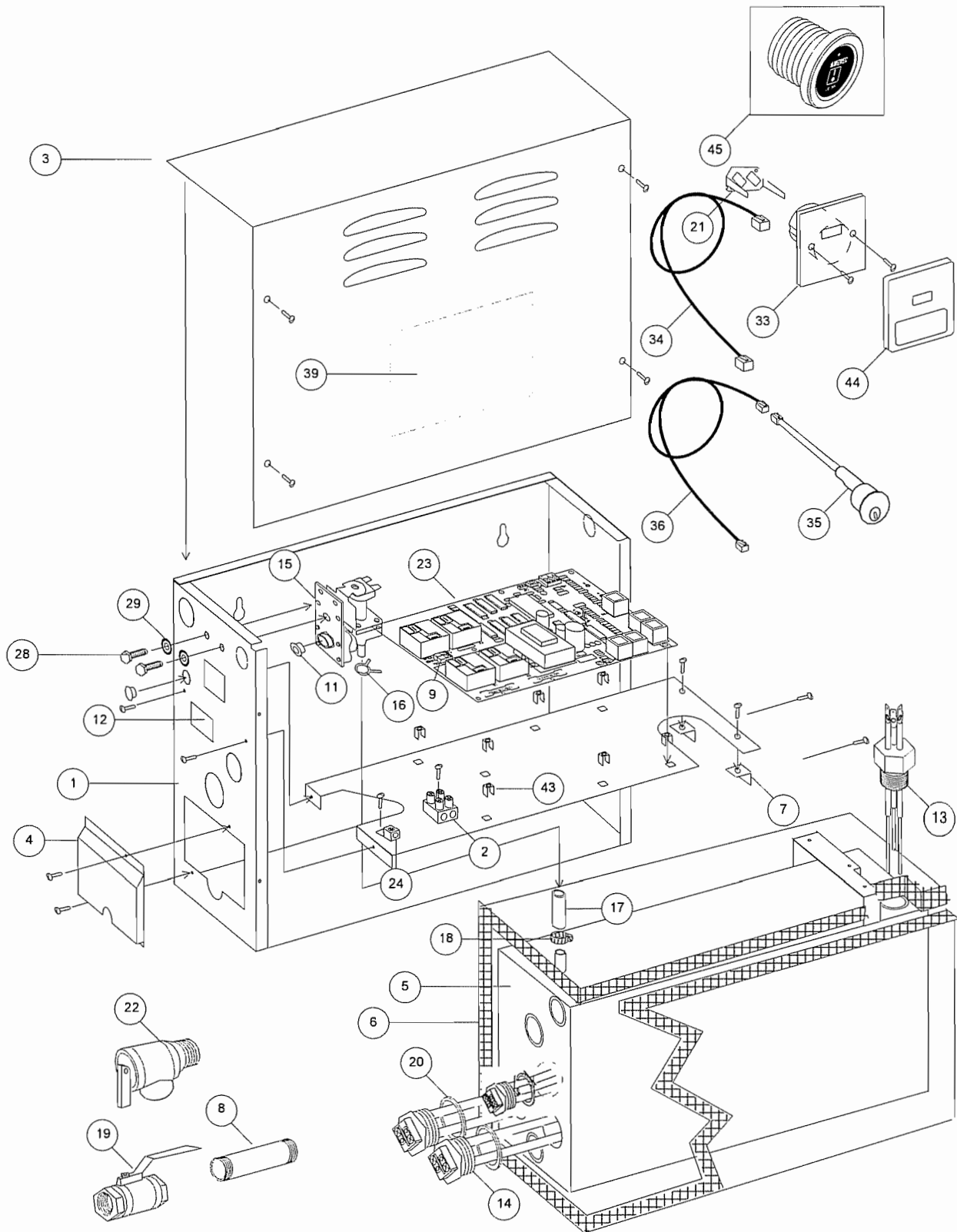

PARTS LIST (AK GENERATOR)

NUMBER	PART NAME	DESCRIPTION
1	FRAME	CHASSIS
2	TERMINAL	POWER INPUT TERMINAL BLOCK
3	COVER	FRONT WITH WD LABEL
4	COVER	ELEMENT ACCESS
5	TANK	TWO ELEMENTS
6	INSULATION	BLANKET
7	BRACKET	L BRACKET
8	NIPPLE	DRAIN NIPPLE
9	TERMINAL	OPTIONAL AUTO FLUSH TERMINAL BLOCK
11	CAP	CAP, THREAD PROTECTOR
12	LABEL	UL RATING
13	PROBE	TRIPLE LEVEL
14	ELEMENT	REPLACEABLE ELEMENT
15	VALVE	WATER INLET
16	CLAMP	SELF-TIGHTENING
17	HOSE	WATER
18	CLAMP	AUGER
19	VALVE	MANUAL DRAIN
20	GASKET	ELEMENT
21	BRACKET	MOUNTING BRACKET
22	VALVE	PRESSURE RELIEF
23	PCA	"BLACK" PRINTED CIRCUIT ASSEMBLY, 3K
24	LUG	GROUND
28	BOLT	1/4-20 x 1/2"
29	WASHER	1/4" LOCK
33	CONTROL HOUSING	CONTROL HOUSING
34	CABLE	CONTROL CABLE
35	SENSOR	TEMPERATURE SENSOR (K30 & K60 ONLY)
36	CABLE	TEMPERATURE SENSOR CABLE (K30 & K60 ONLY)
37	STEAM HEAD	DISPERSION HEAD (NOT SHOWN)
38	PLACARD	SAFETY (NOT SHOWN)
39	LABEL	WIRE DIAGRAM
40	FUSES	15/100 SLO-BLO (NOT SHOWN)
41	FUSES	3A SLO-BLO (NOT SHOWN)
43	STANDOFF	STAND OFF
44	COVERPLATE	DECORATIVE CONTROL COVER PLATE
45	CONTROL	R30K CONTROL

PARTS AND/OR RETURNS

• For assistance or parts ordering, please contact your local AMEREC Dealer or AMEREC at 1-800-331-0349. Please help us to serve you better by:

1. Identifying the problem by using the troubleshooting guide in this manual.

2. Read Number 12, the UL Ratings Label, to obtain your unit's model and code number.

3. When ordering parts, please provide the number, description and quantity needed. When ordering wires or wire assemblies, please describe the wires by color, location and / or their connection points.

4. Do not return any material to AMEREC without first contacting AMEREC for a Return Authorization Number. Freight must be prepaid to AMEREC.

PARTS LIST (AG GENERATOR)

NUMBER	PART NAME	DESCRIPTION
1	FRAME	CHASSIS
2	TERMINAL	POWER INPUT TERMINAL BLOCK
3	COVER	FRONT WITH W/D LABEL
4	COVER	ELEMENT ACCESS
5	TANK	TWO ELEMENT
6	INSULATION	BLANKET
7	BRACKET	L BRACKET
8	NIPPLE	DRAIN NIPPLE
9	TERMINAL	OPTIONAL AUTO FLUSH TERMINAL BLOCK
11	CAP	CAP, THREAD PROTECTOR
12	LABEL	UL RATING
13	PROBE	TRIPLE LEVEL
14	ELEMENT	REPLACEABLE ELEMENT
15	VALVE	WATER INLET
16	CLAMP	SELF TIGHTENING
17	HOSE	WATER
18	CLAMP	AUGER
19	VALVE	MANUAL DRAIN
20	GASKET	ELEMENT
21	BRACKET	MOUNTING BRACKET
22	VALVE	PRESSURE RELIEF
23	PCA	"BLACK" PRINTED CIRCUIT ASSEMBLY, AG
24	LUG	GROUND
28	BOLT	1/4-20 x 1/2"
29	WASHER	1/4" LOCK
37	STEAM HEAD	STEAM DISPERSION HEAD (NOT SHOWN)
38	PLACARD	SAFETY (NOT SHOWN)
39	LABEL	WIRE DIAGRAM
40	FUSES	15/100 SLO-BLO (NOT SHOWN)
41	FUSES	3A SLO-BLO (NOT SHOWN)
43	STAND OFF	STAND OFF
44	CABLE	SLAVE CONTROL CABLE (NOT SHOWN)

PARTS AND/OR RETURNS

• For assistance or parts ordering, please contact your local AMEREC Dealer or AMEREC at 1-800-331-0349. Please help us to serve you better by:

1. Identifying the problem by using the troubleshooting guide in this manual.

2. Read Number 12, the UL Ratings Label, to obtain your unit's model and code number.

3. When ordering parts, please provide the number, description and quantity needed. When ordering wires or wire assemblies, please describe the wires by color, location and / or their connection points.

4. Do not return any material to AMEREC without first contacting AMEREC for a Return Authorization Number. Freight must be prepaid to AMEREC.

2 ELEMENT STEAM SYSTEM WIRING DIAGRAM

2 ELEMENT STEAM GENERATOR WIRING DIAGRAM

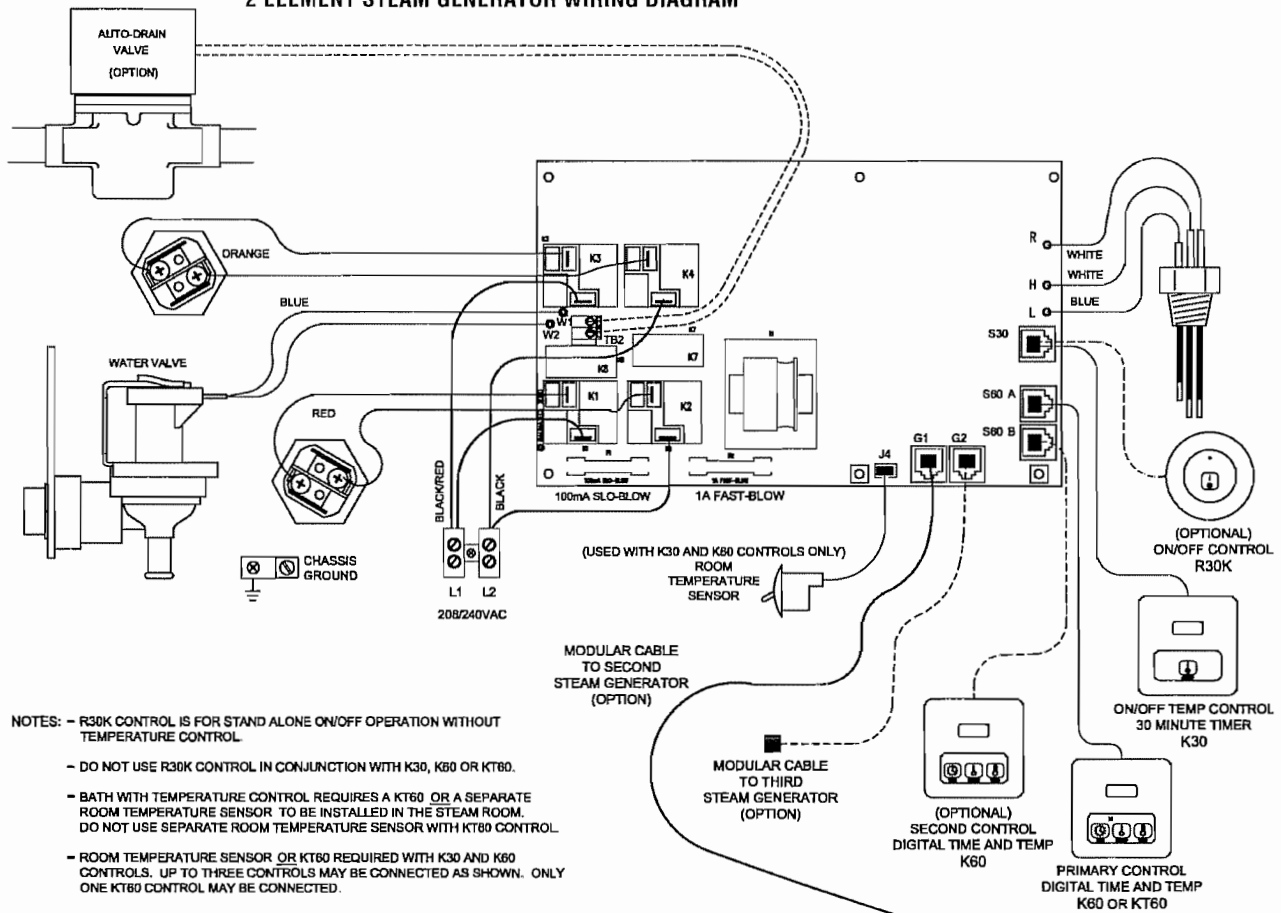

GANG CONTROLLED STEAM GENERATOR WIRING DIAGRAM

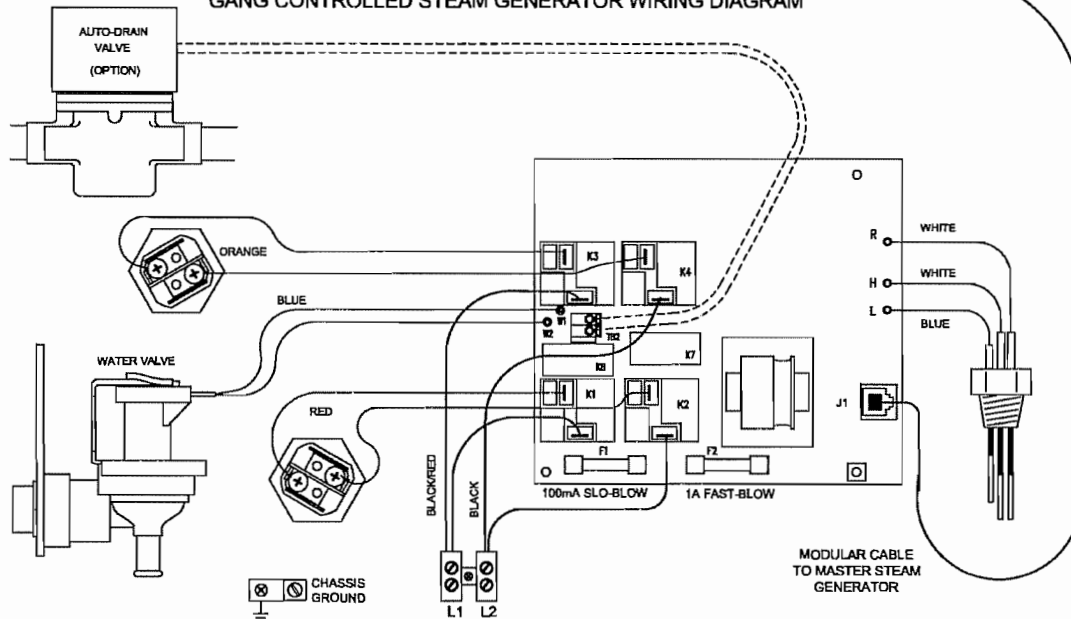

3 ELEMENT STEAM SYSTEM WIRING DIAGRAM

3 ELEMENT 3 PHASE STEAM GENERATOR WIRING DIAGRAM

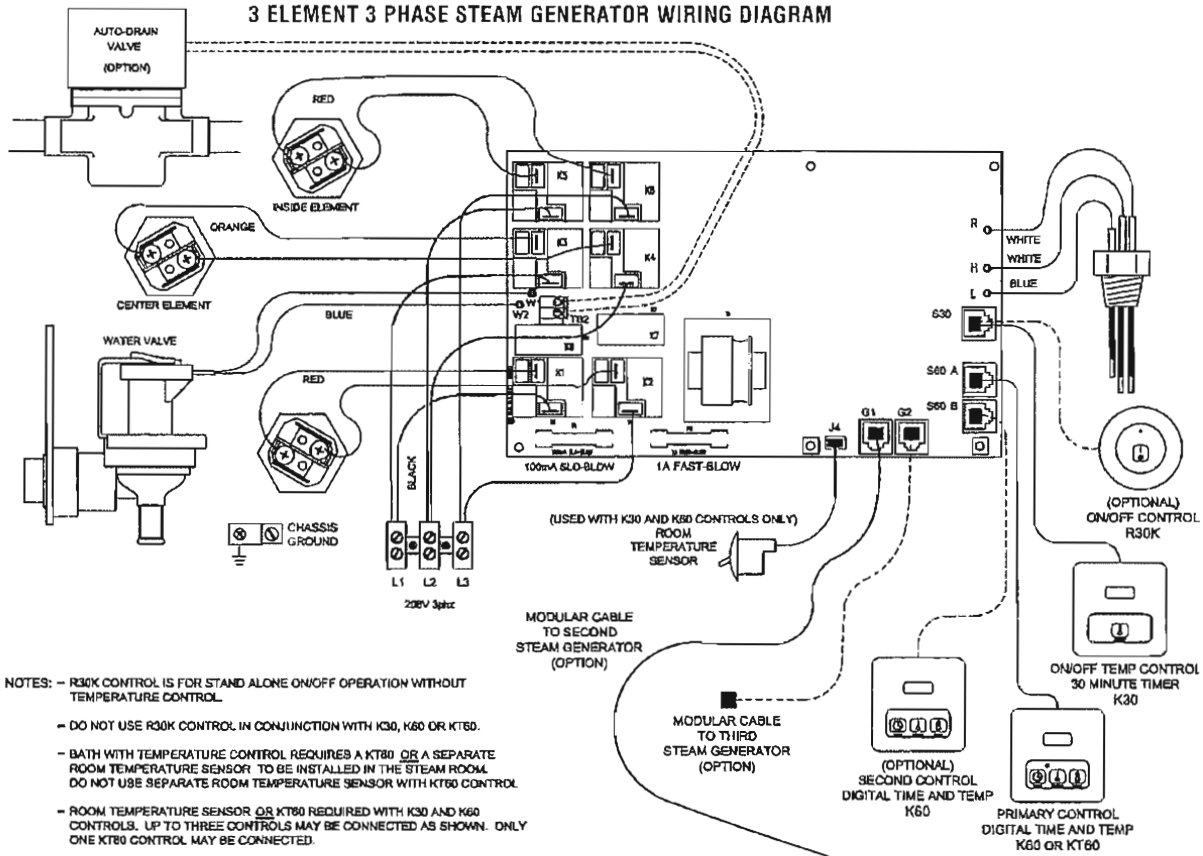

- NOTES: - R30K CONTROL IS FOR STAND ALONE ON/OFF OPERATION WITHOUT TEMPERATURE CONTROL.
- DO NOT USE R30K CONTROL IN CONJUNCTION WITH K30, K60 OR K760.
 - BATH WITH TEMPERATURE CONTROL REQUIRES A K760 OR A SEPARATE ROOM TEMPERATURE SENSOR TO BE INSTALLED IN THE STEAM ROOM. DO NOT USE SEPARATE ROOM TEMPERATURE SENSOR WITH K760 CONTROL.
 - ROOM TEMPERATURE SENSOR OR K760 REQUIRED WITH K30 AND K60 CONTROLS. UP TO THREE CONTROLS MAY BE CONNECTED AS SHOWN. ONLY ONE K760 CONTROL MAY BE CONNECTED.

GANG CONTROLLED STEAM GENERATOR WIRING DIAGRAM

